

NASA's Evolutionary Xenon Thruster (NEXT) Ion Propulsion System Information Summary for Discovery Missions August 2009

1. NEXT INTRODUCTION

This document is a guide to Discovery mission proposal teams. The document describes the development and status of the NASA's Evolutionary Xenon Thruster (NEXT) ion propulsion system (IPS) technology, its application to planetary and science missions, and the process anticipated to transition NEXT to the first flight mission.

1.1 Background

The NEXT ion propulsion system is an advanced technology development under the NASA Science Mission Directorate In-Space Propulsion Technology (ISPT) project since 2001. The primary objective of the Next project is to increase significantly performance for primary propulsion to planetary bodies by leveraging NASA's very successful ion propulsion program for low-thrust applications. The project was awarded through the ROSS 2001 NASA Research Announcement (NRA), A.9.2 Next Generation Ion Engine Technology. The NEXT technology was developed through a two-phase project. The first phase, demonstrating proof-of-concept at the breadboard level, was successfully completed in 2003. This led to the second phase, development to Technology Readiness Level (TRL) 5/6. The government/industry team completed the highest fidelity hardware planned, including a flight prototype model (PM) thruster, an engineering model (EM) power processing unit, EM propellant management assemblies, a breadboard gimbal, and control unit simulators. Subsystem and system level technology validation testing is nearing completion. To achieve the objective Technology Readiness Level 6, the team is conducting environmental testing to qualification levels in ground facilities simulating the space environment.

NEXT is an advanced ion propulsion system oriented towards robotic exploration of the solar system using solar-electric power. It is based on an evolutionary design which has strong heritage to the NSTAR (NASA's Solar Electric Propulsion Application Readiness) IPS that is currently flying on the Dawn spacecraft. Potential mission destinations that can benefit from a NEXT Solar Electric Propulsion (SEP) system include inner planets, small bodies, as well as outer planets and their moons when chemical or aerocapture approaches are used for orbit capture at the destination body. This range of robotic exploration missions generally calls for ion propulsion systems with deep throttling capability and system input power ranging from 5 to 25 kW, as referenced to solar array output at one Astronomical Unit (AU).

1.2 System Summary

The NEXT technology development project focuses on those elements of an ion propulsion system that are most applicable to a range of mission concepts and have the greatest technology development risks. Figure 1 illustrates the NEXT project products in a representative, simplified, system configuration. This figure represents the subset of an overall ion propulsion system that the NEXT project team addressed. Appendix J of the "NASA Procedural Requirements (NPR) 7120.8 NASA Research and Technology Program and Project Managements Requirements" provides the definition of technology hardware maturity. Table 1 describes the various major subsystems of a flight ion propulsion system (IPS), and the hardware maturity (per NPR 7120.8) achieved on the NEXT project. This document retains the hardware maturity terminology used in prior NEXT publications, as shown in Table 1.

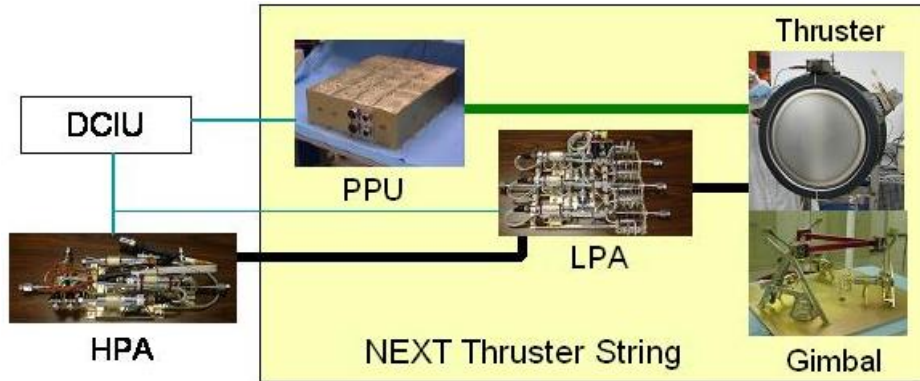

Figure 1. NEXT ion propulsion system elements

Table 1. NEXT Subsystems

IPS Subsystem	Function	NEXT Hardware Maturity (per project terminology)	NEXT Hardware Maturity (per NPR 7120.8)
Ion Thruster	Provide thrust	Prototype Model	Engineering Unit
Power Processing Unit	Converts solar array power to thruster input power	Engineering Model	Engineering Unit
Propellant Tank	Xenon storage	Not addressed on NEXT	Not addressed on NEXT
High Pressure Assembly	Control xenon pressure to LPA	Engineering Model	Engineering Unit
Low Pressure Assembly	Control xenon flow to thruster	Engineering Model	Engineering Unit
Miscellaneous valves, tubing and fitting	Xenon loading, isolation control and purge flow	Not addressed on NEXT	Not addressed on NEXT
Gimbal	Point thruster to desired vector	Breadboard	Brassboard
Control/Interface Unit	Control/data interface to spacecraft, PPU and xenon feed system	Simulator only, with brassboard xenon flow control cards	Simulator only, with brassboard xenon flow control cards

1.3 Subsystem Summaries

The following subsections provide a summary description of the NEXT subsystems. The specification sheets in Appendix A include additional information such as key performance characteristics, mass, dimensions, and subsystem test parameters.

1.3.1 Ion Thruster

The NEXT ion thruster was developed through a two-phase approach. NASA Glenn Research Center (GRC) developed the initial design concept and validated it through fabrication and test of five Engineering Model (EM) thrusters. GRC transferred the thruster concept to Aerojet for implementation in the PM thruster design and hardware. Aerojet delivered the first thruster article, PM1, to NASA GRC in January 2006. Key validation activities include performance acceptance testing, environmental analysis and testing, and life analysis and testing. Figure 2 shows the

NEXT PM thruster operating during performance acceptance testing.

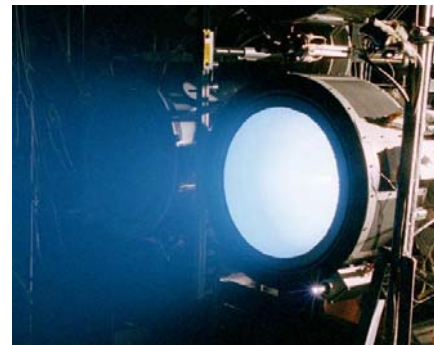

Figure 2. NEXT PM thruster during performance acceptance testing

1.3.2 Power Processing Unit

L-3 Communications designed and fabricated the engineering model (EM) power processing unit (PPU) for the NEXT project as shown in Figure 3. This modular PPU is capable of processing from 0.5 to 7.0 kW of output power for operating the NEXT ion thruster. Its design includes many significant improvements for better performance over the state-of-the-art NSTAR PPU. The most significant difference is the beam supply that is comprised of six modules and is capable of very efficient operation through a wide power and voltage range. The previously validated NSTAR PPU provided the basis for the low voltage power supplies. The modular construction of the PPU resulted in improved manufacturability and simpler scalability.

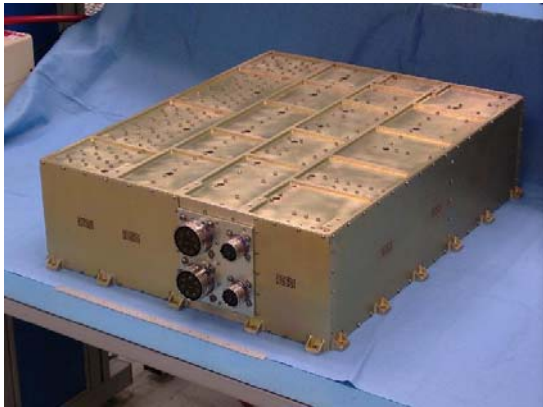

Figure 3. NEXT EM PPU

1.3.3 Propellant Management System

Aerojet designed and fabricated the NEXT EM high pressure and low pressure assemblies (HPA, LPA) and the primary flow control components of an overall xenon feed system. Both assemblies are shown in Figure 4. The HPA, composed of parallel redundant proportional flow control valves (PFCV) and pressure transducers, steps the xenon pressure from tank pressure to a nominal regulated LPA inlet pressure of 35 psia, or provides unregulated pressure below 35 psia for end-of-mission operations. The LPA consists of three flow-control kernels to supply throttled xenon flow to the thruster main plenum, discharge cathode and neutralizer cathode. The composition of each kernel consists of a PFCV, pressure transducer and thermal throttle. Latch valves between each kernel provide the capability to operate the thruster with a failed-closed PFCV, as well as provide pressure transducer cross-calibration capability. Initial validation of the propellant management system (PMS) technology was accomplished during breadboard system integration testing in the first NEXT project phase in 2003. EM assemblies were fabricated and tested in the project phase 2. Key PMS validation activities include performance acceptance and environmental testing, all of which were completed.

1.3.4 Gimbal

ATK (then Swales Aerospace), under contract to the Jet Propulsion Laboratory (JPL), designed and fabricated the NEXT gimbal. Swales delivered one complete gimbal assembly with sufficient parts for a second assembly. The gimbal provides maximum angular authority of $\pm 19^\circ$ and $\pm 17^\circ$ about the primary gimbal axes and a rough cone about the thruster centerline within those boundaries. The NEXT gimbal has a significantly smaller spacecraft interface footprint as compared to the Dawn/NSTAR gimbal.

1.3.5 Digital Control Interface Unit

The NEXT project developed a simulator for the system Digital Control Interface Unit (DCIU), providing the capability to operate the key technology products in an integrated system. The primary functions of the DCIU is to interface to the spacecraft flight processor for high level commands and telemetry, and to control the PPU and PMS assemblies, effectively throttling the ion thruster(s). The NEXT DCIU simulator contains the brassboard-level analog cards that control the HPA and LPA pressure control loops.



Figure 4. NEXT EM High Pressure Assembly (top) and Low Pressure Assembly (bottom) from the Propellant Management System

2. PERFORMANCE SUMMARY

2.1 Performance Characteristics

The NEXT ion propulsion system can be tailored to a wide range of mission applications. The following attributes are the primary contributors to ion propulsion system performance.

2.1.1 Thruster Performance

Thrust and specific impulse are the primary measures of effective conversion of power and propellant to offset the required mission velocity change (ΔV). A summary of the NEXT thruster performance is in the specification sheet found in Appendix A. Additional detailed throttle table data is available upon request.

2.1.2 Thruster Lifetime

Xenon throughput is the primary measure of ion thruster lifetime. Specific thruster wear-out modes exist that relate directly to throughput. The NEXT project requirement, based on a range of mission analyses, is for a qualified throughput of 300 kg per thruster. Projection of the first wear-out failure of the NEXT thruster is to occur at greater than 750 kg xenon throughput for the majority of the throttle

table. This provides a qualified capability of greater than 500 kg throughput. For the three lowest power throttle points, as listed in Appendix A, throughput capability is less than 750 kg xenon due to unique wear mechanisms. However, with the low xenon flow rates at these throttle points, first failure is projected to be at greater than 45,000 hours of operation at any of these conditions.

Thruster lifetime in throughput can be converted to total impulse by considering average-mission thruster power, as depicted in Figure 5. For example, assuming the projected thruster throughput rating of 500-kg xenon, a single thruster can provide approximately $1.3\text{--}2.1 \times 10^7$ N-s total impulse, the range being a function of input power and throttling approach. Increased total impulse per thruster provides the capability to do higher ΔV missions with fewer thrusters.

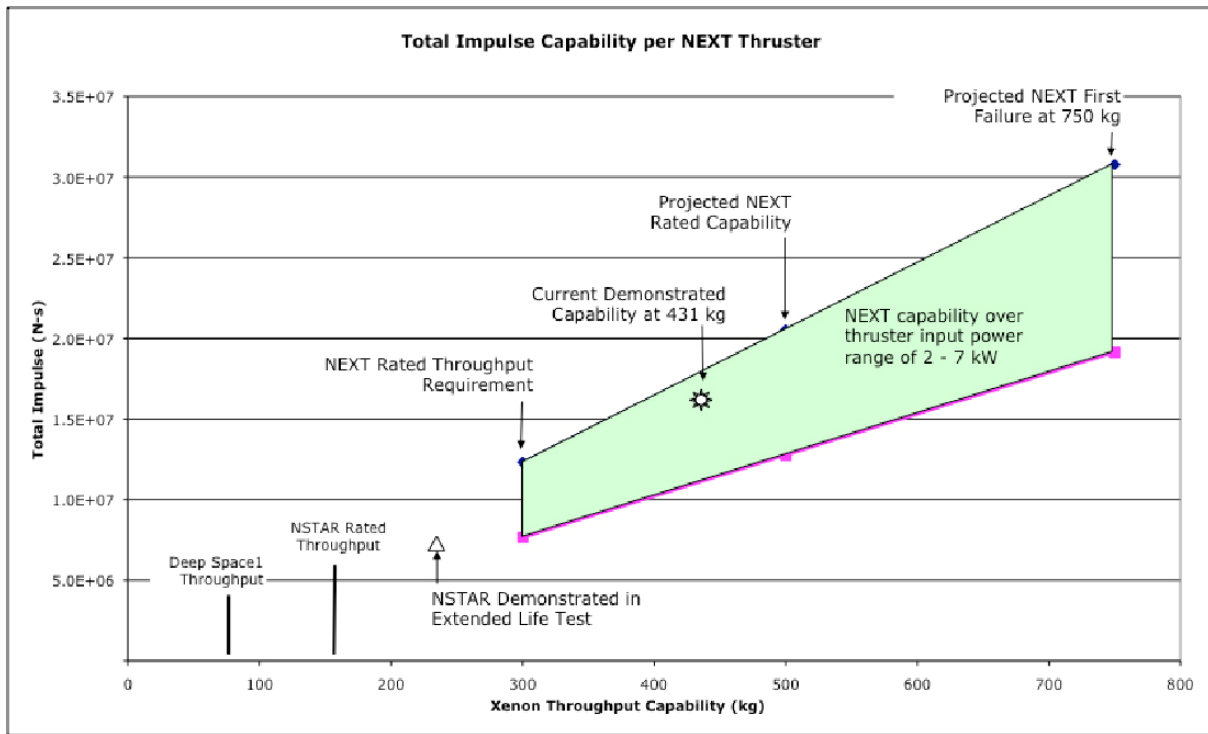

Figure 5. NEXT Thruster Total Impulse Capability

2.1.3 Ion Propulsion System Input Power

The sizing of the solar arrays, and the resulting power dedicated to propulsion, is a primary factor in system performance optimization.

2.1.4 PPU Efficiency

Efficient conversion of array power to thruster power is important in achieving overall IPS performance. A summary of the PPU efficiency over the power throttle range is in the attached specification sheet found in Appendix A. The NEXT PPU accepts unregulated primary power over a range of 80-160V. This eliminates power losses associated with an external power regulation unit.

2.1.5 IPS Throttle-ability

NEXT supports throttling of a thruster over a power range of 540 W to 6.9 kW. This provides an important capability to operate in single thruster mode over a large range of heliocentric distances. The thruster and PPU also provide a flexible throttling capability at a given input power to control the thruster operations in a high thrust-to-power mode or a high specific impulse mode. This provides additional flexibility in achieving challenging missions with optimum performance. Throttle range data is included in Appendix A. Finally, adding multiple thruster/PPU/LPA strings expands the ion propulsion system throttle range by

permitting simultaneous operation of multiple thrusters to achieve the optimum ΔV .

2.1.6 IPS Dry Mass

The dry masses of a representative NEXT- based ion propulsion system are tabulated in Table 2. While IPS dry masses are generally greater than a chemical system, the

specific impulse of NEXT results in a significantly lower wet mass for a given ΔV .

The optimum NEXT ion propulsion system configuration and performance is established through low thrust trajectory analysis, which must be conducted for specific mission concepts and constraints.

Table 2. Component List for NEXT Characteristics for a Two-Thruster String Mission

Description	QTY	Unit Mass		Current Best Estimate Mass		Data Source
		(kg)	(lbm)	(kg)	(lbm)	
Saturn SEP Spacecraft Propulsion Subsystem – Dry Mass				153.9	339.3	
EP Thrusters				37.4	82.5	
Primary EP thrusters	2	12.7	28.0	25.4	56.0	NEXT Development Team
Electric Propulsion system Structure			0.0	0.0	0.0	
EP Thruster Gimbal	2	6.0	13.2	12.0	26.5	NEXT Development Team
Electric Propulsion system Thermal control subsystem				3.4	7.5	
Tank MLI	2	0.1	0.2	0.2	0.4	Calculated Hardware
Tank Heaters	2	1.0	2.2	2.0	4.5	Calculated Hardware
Line MLI	1	0.4	0.9	0.4	0.9	Calculated Hardware
Line Heaters	1	0.8	1.7	0.8	1.7	Calculated Hardware
Propellant Management				40.9	90.1	
Xe Propellant Tank(s)	2	14.2	31.3	28.4	62.5	Based on ATK-PSI Tank 80465-1; sizing based on curve fit to COTS hardware
Feed System				12.5	27.5	
Low Pressure Assembly Module	2	3.1	6.8	6.2	13.7	NEXT Development Team
High Pressure Assembly Module	1	1.9	4.2	1.9	4.2	NEXT Development Team
Propellant Lines –High Pressure	2	0.0	0.1	0.1	0.1	Calculated Hardware
Propellant Lines – Low Pressure	1	0.2	0.4	0.2	0.4	Calculated Hardware
Isolation Valve for each Thruster Pod	3	0.2	0.4	0.6	1.3	Based on MOOG 51-212 latch valve
Service Valves – Latching	4	0.2	0.4	0.7	1.5	Based on MOOG 51-212 latch valve
Line Filters	4	0.1	0.2	0.4	0.9	Hardware Approximation
Fill/Drain Lines	2	0.3	0.6	0.6	1.3	Calculated Hardware
DCA/NCA Purge Lines	4	0.2	0.4	0.6	1.4	Calculated Hardware
Service Line Quick Disconnects	2	0.2	0.5	0.4	0.9	Based on MOOG Service Valve, high pressure
Purge Line Isolation Valve – Manual	4	0.2	0.5	0.8	1.8	Based on MOOG Service Valve, low pressure
Power Processing Unit (PPU)				74.6	166.7	
PPU Mass	2	33.9	75.9	67.8	151.7	NEXT Development Team
Cabling	1	6.8	15.0	6.8	15.0	Calculated Hardware

3. DEVELOPMENT SUMMARY (UNDER ISPT)

3.1 Approach/Strategy

The motivation of the NEXT project is to develop a highly capable, ion propulsion system. The objectives were to develop an evolutionary design with strong heritage to the flight-demonstrated NSTAR IPS. Advancements would address key limitations to SOA design (NSTAR), namely by increased throughput, increased power throttle range, increase performance and improved system mass.

The overall aim is to advance the NEXT IPS components from TRL 3 (analytical and experimental critical function and/or characteristic proof-of-concept) to TRL 6 (system/subsystem model or prototype demonstration in a relevant environment – ground or space), including a full system-level demonstration of an end-to-end string of IPS components operated in a relevant environment.

The component development consists of design, fabrication and testing of the engineering/prototype model hardware. Component testing includes performance characterization

tests, vibration test, thermal-vacuum, and thermal cycle tests with performance verification tests periodically performed.

3.2 Hardware Status

The status of the individual components is provided as well as the status of the system level demonstrations.

3.2.1 Thruster

A laboratory model 40-cm diameter ion thruster developed in 2001 provided the basis for the engineering and prototype-model ion thruster designs. GRC subsequently developed the EM design. Aerojet developed the PM design, under contract to GRC, with the objective to mature NEXT thruster design to ensure full-compliance with structural and thermal requirements and to improve thruster manufacturability. Aerojet delivered the PM1 thruster to GRC following flight-level design and fabrication processes.

GRC successfully completed performance acceptance testing followed by a comprehensive environmental test sequence at JPL. GRC and JPL completed two cycles of acceptance and environmental tests in order to resolve minor design issues with thruster rework. The reworked thruster used in the second cycle of environmental tests was designated PM1R. Thruster environmental tests included a thermal balance test to gather key thruster temperature maps over a wide range of operating and environmental conditions. Information was used to develop and validate thruster thermal model and demonstrate temperature margins over a large temperature range. Vibration of the thruster/gimbal assembly to qualification-level vibration environments (10.0 G_{rms} for two minutes in each axis) was completed with no changes in thruster performance functionality. Thermal-vacuum tests were completed to qualification levels with a lower temperature limit set point of -120°C (cold), and an upper temperature limit set point of 215°C (hot). The thruster was subjected to three cycles with hot and cold dwell and was started at both hot and cold temperature limits. PM1R was integrated into the System Integration Test (SIT) and has completed into a short duration wear test with a duration of over 1600 hours.

PM thruster drawings and work instruction were updated to incorporate redlines and to reflect PM1R as-built configuration and were released to development level. PM2 parts and subassemblies are in controlled storage for future use.

3.2.2 Power Processing Unit (PPU)

L-3 Communications completed the engineering model PPU. Performance/functional testing at vacuum conditions was completed successfully. The PPU was then integrated into the SIT. During the SIT, and in subsequent testing, the PPU has suffered two likely unrelated part failures. The first failure is resolved, the second resolution is currently in progress. After resolution of this issue, the PPU will be re-

tested with the NEXT PM thruster, also addressing the last objectives of the SIT. After these PPU acceptance tests, a comprehensive series of environmental tests at JPL will follow. The environmental tests include qualification-level vibration tests with post-vibration functionality test, qualification-level thermal/vacuum test with post-thermal/vacuum functionality test, and electromagnetic interference/electromagnetic compatibility (EMI/EMC) tests. PPU environmental testing is planned to be complete in CY2009.

3.2.3 Propellant Management System (PMS)

Aerojet completed all engineering model PMS assemblies, including two High Pressure Assemblies (HPAs), with one flight-like assembly, and three Low Pressure Assemblies (LPAs) with one flight-like assembly. The non-flight assemblies are identical except for use of lower-cost equivalent parts. All assemblies completed functionality tests. Flight-like LPA and HPA successfully completed qualification-level environmental tests. The environmental tests included qualification-level vibration tests (at 14.1 G_{rms} for two minutes in each axis) and post-vibration functionality tests as well as qualification-level thermal/vacuum tests (+12° to +70°C temperature range for three cycles). The EM PMS was delivered to NASA and was incorporated into system integration tests.

3.2.4 Digital Control Interface Unit (DCIU)

DCIU simulators were completed and are used in subsystem- and system-level tests. The simulator is personal computer-based test equipment with brassboard-level PMS pressure loop control cards, and is capable of operating a three-thruster string system. The DCIU simulator supports validation of control algorithms and the PMS control card design.

3.2.5 Gimbal

Swales Aerospace designed and fabricated the breadboard gimbal. It is a flight-like design using JPL-approved materials with certifications, and stepper motors have a space-rated option. The design of the gimbal was as a flight-packaged unit without substantive thermal analysis. Therefore, only functional testing and structural dynamic analyses and testing were performed on the gimbal. The gimbal successfully completed functionality tests with the PM1R engine. The gimbal passed two qualification-level vibration tests and low-level shock tests with minor issues. This establishes a baseline design, with few modifications needed to move into a qualification program.

3.3 Key activities (Summary)

3.3.1 Thruster Life Validation activities

The NEXT thruster life validation is performed through a combination of test and analysis. An engineering model thruster (EM3) operates in a Long Duration Test (LDT) in Vacuum Facility 16 at GRC. The thruster has a high degree

of similarity to the Aerojet PM thruster in elements related to thruster wear mechanisms. EM3 has Aerojet-manufactured prototype-model ion optics. The cathode assemblies replicate the geometry and materials of the elements of the PM units that are exposed to wear. The discharge chamber is geometrically identical and has the same magnetic circuit design. This supports direct translation of LDT results to the flight-build thrusters. The thruster has demonstrated over 24,000 hours of operation or over 431 kg of xenon throughput as of August 14, 2009. This represents a total impulse $>16.1 \times 10^6$ N-s. The demonstration exceeded the project design goal of 300 kg in March 2008, with planned operation to continue to 450 kg by the end of CY09. The thruster operates at different throttle conditions to characterize erosion rates over the entire range of the throttle table. ISPT funding for the LDT continues through FY12, with the aim of demonstrating up to 750 kg of xenon throughput.

In parallel to the tests, computational models were developed, incorporating LDT data, to predict total xenon throughput capabilities of the thruster design. The models simulate wear mechanisms and rates of critical thruster components, such as ion optics, discharge keeper, etc. These models are continually updated with the latest experimental data as it is collected. The predicted capability of the thruster exceeds 750 kg of xenon throughput.

3.3.2 System Integration Tests

The three test activities categorized as system-level tests are multi-thruster array tests, a single-string system integration tests (SSIT) and multi-string system integration tests (MSIT). The objective of the multi-thruster array test was to assess thruster and plasma interactions with sensitivities to thruster spacing, gimbaled thrusters and neutralizer operating modes. The configuration included four GRC EM thrusters; three operating and one instrumented non-operating as well as an extensive suite of diagnostics to collect data for multi-thruster system modeling and analyses. The multi-thruster array test was completed in December 2005 and included single, dual, and triple thruster operations. Results indicate that expected thruster performance was achieved and thruster operations were understood without significant sensitivity to system configuration.

The scope of the Single-String System Integration Test (SSIT) was to verify that the integrated system of NEXT components meets the project requirements in a relevant environment. The primary objectives were to demonstrate:

- operation of the thruster over the throttle table with PPU and PMS,
- operation of system at off-nominal conditions, and
- recycle and fault protection operation;

and to verify a wide range of system-level requirements, including functional, performance, environmental and

interface requirements. The test configuration included the PM thruster, EM PPU, the EM PMS as well as the DCIU simulator. The test started in May 2008 and continued through August when the aforementioned PPU part failure interrupted the test sequence. Testing that did not require the PPU was then completed, resulting in completion of 70-80 percent of the test objectives. Upon completion of the PPU recovery, the balance of the SSIT objectives will be addressed.

A Multi-string System Integration Test (MSIT) was conducted immediately following the SSIT, demonstrating successful operations of three thrusters (PMIR and two EM thrusters) with the PMS HPA and three LPAs controlled by the DCIU simulator.

3.4 Planned ISPT tasks

The planned ISPT tasks remaining for NEXT development primarily include completely of PPU testing and continuation of the Long Duration Test. The Phase 2 project will be formally completed with two significant reviews, a Phase-2 Close-out Review and a Technology Maturity Assessment. Both reviews support the processes defined NPR 7120.8 for technology project management. The entirety of the Phase 2 development activities will be reviewed to evaluate the completion of project objectives and to establish the TRL of the system. In addition, the group will identify, assess and prioritize any perceived high-risk items so that the balance of project resources, available after the completion of all Phase 2 tasks, will be applied to risk reduction activities in FY10 and beyond. The reviews will have panels comprised of electric propulsion technical peers and representatives from the mission-user community.

3.5 Timetable for Completing TRL 6

The project objective is to complete Phase 2 of the NEXT technology development project in CY2009, as driven by the PPU recovery activities. Successful completion of the remaining PPU/Thruster integration tests, and PPU environmental testing will complete the planned test sequence, with the EM thruster long duration test continuing into the future. Further, successes in these tests will bring the thruster, PPU, and PMS HPA and LPA to TRL 6, validated in a relevant environment in a relevant system configuration. The Technology Maturity Assessment will provide an independent determination of NEXT TRL. Remaining shortcomings, in any, can readily be addressed in FY10 risk reduction tasks and subsequent ISPT or Discovery mission tasks prior to mission PDR.

3.6 Dawn lessons learned/Independent Review

One of the primary concerns that users have with new technology is cost growth in mission implementation. This is especially relevant for the potential users of electric propulsion given the cost growth experienced by the Dawn project. Project activities conducted to increase the

likelihood of transitioning the NEXT IPS technology to flight in the near term were:

1. reviewing a compilation of lessons learned from the Dawn experience and developing strategies to mitigate the likelihood of experiencing similar difficulties,
2. conducting independent reviews of NEXT technology status with representation from the user community and incorporating the feedback into the development plan, and
3. identifying additional technology development and validation activities which may be of value in transitioning the TRL-6 IPS technology to flight and reduce barriers to first-user implementation by reducing non-recurring costs, etc.
4. establishing an agreement with the Aerospace Corporation to perform independent thruster characterization tests.

The NEXT project team placed particular emphasis on key aspects of IPS development with the intention of avoiding the difficulties experienced by the Dawn mission in transitioning the NSTAR-based technology to an operational IPS.

Specific examples of Dawn lessons learned are in Table 3.

Table 3. Lessons learned from Dawn Mission

Dawn Problem	NEXT Mitigation Strategy
Documentation -- Inadequate thruster and PPU documentation	EM PPU manufactured by flight production group with all documentation (manufacturing drawings and assembly instructions) under configuration control. NEXT PM thruster design and assembly documentation updated with PM1R changes and placed under design control for future build cycles.
Propellant management -- Complex, bulky, and required extensive modification to satisfy requirements.	DS-1 and Dawn feed-system engineers heavily involved in design from project initiation; PMS design incorporates a lightweight, compact design.
Thruster -- Complex design elements, difficult to manufacture and assemble. Long duration test results impacted the flight configuration.	Prior to committing to qualification design, extensive tests to evaluate erosion mechanisms were conducted on the EM hardware, resulting in modifications to both EM and PM hardware designs, which continue to undergo extensive evaluation.

4. DISCOVERY MISSION IMPLEMENTATION

4.1 NEXT system definition for your mission concept

A NEXT-based ion propulsion system is designed around thruster strings, each composed of a thruster, a gimbal, a PPU and a feed system LPA. Mission performance optimization and failure tolerance determines the number of thruster strings. Low thrust trajectory optimization is performed to determine the desired number of thruster strings to achieve the objective balance of performance and cost. In many cases, mission analysis results determine that multiple thruster strings, running in parallel, is the optimum approach. A thruster string is also added as a redundant string, to prevent exposure to single point failures. In addition to the thruster strings required, the system is completed with the xenon tank(s), the internally redundant feed system HPA, and the DCIU function. An example ion propulsion system Product Breakdown Structure is shown in Table 4. Selection characteristics for each of these are discussed in more detail below. Information sheets for the thruster, PPU, PMS assemblies and gimbal are also provided in Appendix A.

Table 4. IPS Product Breakdown Structure

1	Spacecraft
1.1	Ion Propulsion System (IPS)
1.1.1	Ion Thruster
1.1.1.1	Discharge Chamber
1.1.1.2	Ion Optics
1.1.1.3	Discharge Cathode
1.1.1.4	Neutralizer Cathode
1.1.1.5	Plasma Screen
1.1.1.6	High Voltage Propellant Isolator
1.1.1.7	Wiring & Tubing
1.1.2	Power Processing Unit
1.1.2.1	Beam Supply
1.1.2.2	Discharge Supply
1.1.2.3	Quad Supply
1.1.2.4	Housekeeping Supply
1.1.2.5	Output Relay Module
1.1.2.6	Input Filter
1.1.2.7	Controller
1.1.2.8	Structure
1.1.2.9	Internal Harness/Connectors
1.1.3	Propellant Management System (PMS)
1.1.3.1	Xenon Tank
1.1.3.2	High Pressure Assembly
1.1.3.2.1	Flow Control Valve
1.1.3.2.2	Pressure Transducer
1.1.3.2.3	Filters, Tubing & Fittings
1.1.3.2.4	Structure
1.1.3.2.5	Internal Harness/Connectors
1.1.3.3	Low Pressure Assembly
1.1.3.3.1	Flow Control Valve
1.1.3.3.2	Thermal Throttle
1.1.3.3.3	Pressure Transducer
1.1.3.3.4	Latch Valve
1.1.3.3.5	Filters, Tubing & Fittings
1.1.3.3.6	Structure
1.1.3.3.7	Internal Harness/Connectors
1.1.3.4	PMS Isolation Valves
1.1.3.5	PMS Service Valves
1.1.3.6	PMS Tubing & Fittings
1.1.3.7	Xenon Loading Equipment
1.1.4	Digital Control Interface Unit (DCIU)
1.1.4.1	HPA/LPA Interface
1.1.4.2	PPU Interface
1.1.4.3	Spacecraft Interface
1.1.5	DCIU Software
1.1.6	Gimbal
1.1.6.1	Stepper Motor/Feedback
1.1.6.2	Flexures
1.1.6.3	Pin Puller
1.1.6.4	Structure
1.1.6.5	Harness and Connectors
1.1.6.6	Xenon Tubing & Fittings
1.1.6.7	Mechanical Support Equipment
1.1.7	IPS Thermal Control
1.1.7.1	Multi-layer Insulation
1.1.7.2	Heaters
1.1.7.3	PPU Baseplate
1.1.8	IPS Integration Hardware
1.1.8.1	PPU/Thruster Harness
1.1.8.2	DCIU/PPU Harness
1.1.8.3	DCIU/XPS Harness
1.1.8.4	Gimbal/Thruster Fasteners
1.1.8.5	XPS/Thruster Fittings

4.1.1 Ion Thruster

The ion thruster is one of the two key elements of the NEXT IPS. The proposer should plan to implement the baseline NEXT thruster produced by Aerojet. The flight build will have a very high degree of similarity to the PM thruster fabricated and tested under the NEXT project. There are limited elements that could be considered for modification without diverging from the TRL validation already achieved. The number of thrusters planned should consider the total xenon propellant throughput required by the mission. Assumptions made are minimum per-thruster capability of 300 kg throughput and greater throughput capability up to 500 kg based on life validation to date, with minor increase in risk. Strategies using the spare thruster string, sharing the overall mission throughput requirement, can increase thruster/IPS life margins, as employed on the Dawn mission.

4.1.2 Power Processing Unit

The PPU is the other key element of the NEXT IPS. The PPU design is specifically for the NEXT thruster. A NEXT PPU can run other ion thrusters, such as NSTAR; but other ion propulsion power processing units cannot operate a NEXT thruster without significant modification and development risk. A single PPU is required for each thruster that operates in parallel, i.e. a PPU cannot operate multiple thrusters simultaneously. The NEXT PPU has an output relay module that directs the power output to one of two thrusters. This provides higher IPS reliability, depending on overall IPS implementation. In addition, in the unlikely event that a mission requires serial use of multiple thrusters due to thruster throughput limitations, this cross strapping allows an architecture in which there are less PPUs than thrusters, as on the Dawn mission. The PPU/thruster harness interface implementing this cross-strapping approach requires further engineering, as was completed on the Dawn mission.

The current PPU status indicates that the final electrical/mechanical implementation of the PPU may change, pending results of remaining tests. These changes would need to be incorporated into the next iteration of the PPU. The NEXT project team has also identified some design changes that can improve the overall PPU that need consideration in the flight-system development project. These primarily relate to housekeeping and fault protection functions, have minimal development risk, and do not affect the primary power processing functions.

Finally, the implementation of the DCIU functionality affects the PPU, as described below.

4.1.3 Propellant Management System

The NEXT project developed a xenon-flow control technology and system architecture approach that differs significantly from the NSTAR state-of-art. The resulting HPA and LPA provide a demonstrated baseline for the key elements of a flight system design. A NEXT IPS, however,

can be successfully implemented with other xenon feed system approaches. The PMS HPA and LPA approach is a recommended option.

4.1.4 Tank-to-thruster PMS Implementation

Tank sizing and selection are a function of the specific mission requirements and spacecraft-bus-interface considerations. They are the responsibility of the proposing team.

Provisions for xenon tank loading are through a service port access between the tanks and the HPA.

The HPA is a single, internally redundant, unit to regulate xenon from the tank pressure to the desired LPA inlet pressure. The HPA implementation, per the current design, represents the simplest PFCV-based approach. The HPA can deliver xenon flow to at least three operating LPAs, as demonstrated in multi-string integration testing. Other approaches are possible to accomplish this function.

The mission development team may elect to install isolation latch valves between the HPA and each LPA. This provides a means to mitigate an LPA external leak, as well as providing another level of isolation of high-pressure xenon gas during ground operations. Using the thruster string associated with that LPA will mitigate the LPA internal leaks. An isolation latch valve can be added though either an LPA design change or as a separate component.

Each thruster requires a dedicated LPA to control the three xenon flows to the thruster. The NEXT LPA provides an internally redundant, robust approach, and can accommodate a single internal failure of a PFCV-closed or thermal throttle temperature sensor or heater. The mission implementation team can elect to simplify the LPA through one of the following approaches:

- elimination of a PFCV, while retaining thermal throttle capability to run both cathodes from a single PFCV,
- replacement of the thermal throttles with passive-thermal-control flow control devices,
- possible elimination of internal latch valves with modifications to other elements of the flow control kernel.

These simplifications can reduce recurring cost, but may increase PMS non-recurring costs due to divergence from the NEXT validated configuration. There is no capability for cross-strapped flow between a single LPA and multiple thrusters. This is feasible, but represents a significant increase in PMS and control system complexity.

NEXT ion thrusters require purge gas flow through the hollow cathodes during all ground operations. Purge ports and service valves installed between each LPA and thruster will satisfy the purge requirements.

In addition to the primary functional elements above, the overall PMS will include tubing, fittings, line heaters, and other purge/service ports to support overall system processing and operations.

4.1.5 Gimbal

The NEXT project developed a gimbal concept that differs significantly from the NSTAR state-of-art. The NEXT gimbal provides a demonstrated baseline for the flight system design. However, other gimbal approaches can meet the requirements of the NEXT IPS. The NEXT gimbal approach is the recommended option.

Spacecraft equipment powers and controls the gimbal as an element of the spacecraft guidance, navigation, and control system. The NEXT gimbal design can be further tailored to specific mission needs, as appropriate.

4.1.6 Digital Control Interface Unit

The mission development team designs the digital control interface function for the first flight of a NEXT IPS. In past NASA missions (Deep Space 1 and Dawn), this function was housed in a separate unit, the DCIU. The Dawn IPS includes a primary and redundant spare DCIU. The In-Space Propulsion Technology project and NEXT project teams considered the possibility of integrating this function into the NEXT PPU. This would likely require a design change to the PPU, with associated development. If the mission implementation team elects to execute a PPU qualification build and test cycle, this would be a good opportunity to incorporate this change. Finally, the mission implementation team may consider allocating DCIU functions to the spacecraft processor.

As the DCIU interfaces to the PPU and PMS, the design of the unit is a function of the selection of the other elements of the NEXT IPS. Selection of the NEXT HPA/LPA architecture allows use of the control card designs implemented in the project DCIU simulator. Use of the NEXT PPU allows use of PPU-interface-card brassboard design currently in progress within ISPT.

The ISPT project is funding a separate activity under Standard Architecture to mature the DCIU hardware and software. Additional information is available upon request.

4.2 Transition to Mission Development

The NEXT project has made substantial progress towards TRL 6 to date. The ISPT project intends to continue funding the NEXT project through FY13, with resources primarily focused on continuation of thruster life validation testing and analysis, but with some resources available for other risk reduction tasks.

4.3 Class B rating approach

Discovery missions have typically been Category 2 missions with Class B (or C) payloads. The NEXT IPS approach is compliant with Class B guidelines, as defined in Appendix B of NPR 8705.4. Assessment of specific guidelines follows.

4.3.1 Single Point Failures

1. A spare thruster string included in the IPS to provide functional redundancy avoids single point failures.
2. The PMS HPA provides that redundancy internal to the assembly.
3. The DCIU function implementation must be compliant with this guidance.
4. The PMS LPA and gimbal both have provisions for partial redundancy and graceful degradation.
 - a. The LPA can maintain the full nominal throttle table flow rates with a PFCV failed-closed, a thermal-throttle-temperature sensor failure or a thermal throttle heater failure.
 - b. The gimbal has a degraded range of motion capability with one of the three-stepper motors failed, and allows for thruster operation in the launch-stowed position if necessary.

4.3.2 Engineering Models, Prototype, Flight and Spare Hardware

The NEXT project completed fabrication of engineering model-level hardware for the thruster, PPU and PMS assemblies, and a high-fidelity breadboard gimbal. Substantial qualification-level testing of these elements was completed as described in previous sections. The proposal team develops the strategy for protoflight versus qualification testing, and for spare hardware. NEXT subsystem sparing can be done at the component, subassembly, or top assembly level.

4.3.3 Qualification, Acceptance, and Protoflight Test Program

Success of the NEXT development activities, including completed qualification-level testing of the thruster and PMS assemblies, provides the opportunity for the mission development team to select protoflight verification strategies. This is in place of extensive and schedule-demanding qualification programs. Successful environmental testing of the EM PPU in 2009 provides similar opportunities. Integrated end-to-end testing of the thruster, PPU, HPA and LPA accomplished under NEXT further reduces the risks to the flight program. The IPS development planning must include the qualification of the DCIU and its associated software.

4.3.4 EEE Parts

The NEXT PPU is compliant with EEE parts requirements. The EM PPU uses only parts that have space-rated equivalents available.

4.3.5 Reviews, Safety, Materials, Mishaps, Reliability, Fault Tree Analysis, Probabilistic Risk Assessment, Maintainability, Quality Assurance, Software, Risk Management, Telemetry Coverage

The NEXT IPS is inherently compatible with these analysis and development processes and objectives. The NEXT technology project team put into practice the elements of these processes to varying degrees. These include formal project reviews, safety planning, materials assessments, reliability analyses, etc. They are available to support transition to a flight project.

4.4 Mission Success

Overall success of the mission determines the success of the NEXT IPS. The NEXT IPS is considered as any other element of the spacecraft bus, and has no less-demanding success criteria.

4. KEY SPACECRAFT INTEGRATION CONSIDERATIONS

Inherent characteristics of electric propulsion systems result in spacecraft integration and interface considerations that vary significantly from standard chemical propulsion systems. In particular, the long duration propulsive arcs associated with electric-propulsion drive mission operations and aspects of spacecraft design. A summary follows for consideration in the mission-concept development process.

5.1 Thermal Control and Design

The NEXT PPU efficiently processes over 7 kW of power at full power operations. This generates a maximum 350 W of waste heat. The spacecraft thermal control system must accommodate an interface design to accommodate the projected thermal load profile.

The desired thrust vector drives the spacecraft attitude during long-duration propulsive arcs, which the trajectory/mission optimization process defines. The overall spacecraft thermal design should consider this effect.

5.2 Spacecraft Power

The IPS uses unregulated 80-160V power for the primary propulsion capability, as well as 28V housekeeping power for selected functions. Depending on the trajectory chosen, the IPS may not use the full high-voltage power generated by the solar arrays at any given heliocentric distance. The spacecraft electrical power system design should allow for full/partial/nil use of high voltage power during the mission.

5.3 Plume Impingement

The spacecraft layout should preclude direct impingement of the thruster ion beam on other spacecraft surfaces.

5.4 Attitude Control

Depending on the number of thrusters operating, and the placement of the thrusters, the gimballed thrust is used to provide partial or full attitude control during propulsive operations. The spacecraft control system powers and controls the gimbals.

5.5 Guidance and Navigation

The long duration propulsive thrust arcs dictate changes in guidance and navigation software design from approaches used for chemical propulsion missions.

5.6 Mission Operations

NEXT mission analyses generally assume a 90 percent duty cycle for propulsive arcs. The other 10 percent is allocated to non-propulsion spacecraft functions. The overall concept of operations must consider the effects of propulsive duty cycle and incorporate that into the trajectory analyses and mission operations planning as appropriate.

5. CONTACT INFORMATION

Please direct all inquiries and requests related to the NEXT engine to the following individual:

David J. Anderson
NASA In-Space Propulsion Technologies Project Office
NASA John H. Glenn Research Center
21000 Brookpark Road, Mail Stop: 77-4
Cleveland, OH 44135
(216) 433-8709
David.J.Anderson@nasa.gov

REFERENCES

- [1] Van Noord, J. and Herman, D. "Application of the NEXT Ion Thruster Lifetime Assessment to Thruster Throttling Strategies" AIAA-2008-4526, 44th AIAA/ASME/SAE/ASEE Joint Propulsion Conference and Exhibit (JPC), Hartford, CT, July 2008.
- [2] Herman, D., Patterson, M., and Soulas, G., "Performance Characteristics of the NEXT Long-Duration Test After 17,200 hours of Operation and 352 kg of Xenon Processed" AIAA-2008-4527, 44th AIAA/ASME/SAE/ASEE JPC, Hartford, CT, July 2008.
- [3] Benson, S., Patterson, and Snyder, J., "NEXT Ion Propulsion System Progress Towards Technology Readiness," AIAA-2008-5285, 44th AIAA/ASME/SAE/ASEE JPC, Hartford, CT, July 2008.
- [4] Herman, D. and Pinero, L., "NASA's Evolutionary Xenon Thruster (NEXT) Component Verification Testing," AIAA-2008-4812, 44th AIAA/ASME/SAE/ASEE JPC, Hartford, CT, July 2008.
- [5] Herman, D., Patterson, M., and Soulas, G. "NEXT Long-Duration Test Plume and Wear Characteristics After 17,200 hours of Operation and 352 kg of Xenon Processed," AIAA-2008-4919, 44th AIAA/ASME/SAE/ASEE JPC, Hartford, CT, July 2008.
- [6] Patterson, M. and Benson, S., "NEXT Ion Propulsion System Development Status and Performance", AIAA-2007-5199, 43rd AIAA/ASME/SAE/ASEE JPC, Cincinnati, OH, July 2007.
- [7] Benson, S., Riehl, J., Oleson, S., "NEXT Ion Propulsion System Configurations and Performance for Saturn System Exploration", AIAA-2007-5230, 43rd JPC, Cincinnati, OH, July 2007.
- [8] Benson, S. and Patterson, M., "Technology Readiness of the NEXT Ion Propulsion System", 2008 IEEE Aerospace Conference, IEEEAC Paper #1479, Big Sky, MT, March 2008.
- [9] Monheiser, J., Aadland, R. and Wilson, A., "Development of a Ground Based Digital Control Interface Unit (DCIU) for the NEXT Propulsion System," AIAA-2004-4112, 40th JPC, Fort Lauderdale, FL, July 2004.
- [10] Aadland, R., Monheise, J., Driscoll, E., Wilson, F., Benson, S., "Development Status of NEXT Propellant Management System," AIAA-2004-3974, 40th JPC, Fort Lauderdale, FL, July 2004.
- [11] Herman, D., Soulas, G. and Patterson, M. "Performance Evaluation of the 40-cm NEXT Prototype Model Ion Thruster", AIAA-2007-5212, 43rd AIAA/ASME/SAE/ASEEJPC, Cincinnati, OH, July 2007.
- [12] Soulas, G., Patterson, M. Van Noord, J., "NEXT Ion Thruster Performance Dispersion Analyses", AIAA-2007-5213, 43rd AIAA/ASME/SAE/ASEE JPC, Cincinnati, OH, July 2007.
- [13] Van Noord, J. and Williams, G., "Lifetime Assessment of the NEXT Ion Thruster", AIAA-2007-5274, 43rd AIAA/ASME/SAE/ASEE JPC, Cincinnati, OH, July 2007.
- [14] Herman, D., Soulas, G., and Patterson, M., "Status of the NEXT Ion Thruster Long-Duration Test", AIAA-2007-5272, 43rd AIAA/ASME/SAE/ASEE JPC, Cincinnati, OH, July 2007.
- [15] Snyder, J., Anderson, J., Soulas, G., and Van Noord, J., "Environmental Testing of the NEXT PM1 Ion Engine," AIAA-2007-5275, 43rd AIAA/ASME/SAE/ASEE JPC, Cincinnati, OH, July 2007.
- [16] Anderson, J., Snyder, J., Van Noord, J., and Soulas, G., "Thermal Development Test of the NEXT PM1 Ion Engine", AIAA-2007-5217, 43rd AIAA/ASME/SAE/ASEE JPC, Cincinnati, OH, July 2007.
- [17] Van Noord, J., "NEXT Ion Thruster Thermal Model", AIAA-2007-5218, 43rd AIAA/ASME/SAE/ASEE JPC, Cincinnati, OH, July 2007.
- [18] Pinero, L., Todd, P. and Hopson, M. "Integration and Qualification of the NEXT Power Processing Unit", AIAA-2007-5214, 43rd AIAA/ASME/SAE/ASEE JPC, Cincinnati, OH, July 2007.
- [19] Pinero, L., Patterson, M., and Sovey, J., "NEXT Thruster Component Verification Testing" AIAA-2007-5276, 43rd AIAA/ASME/SAE/ASEE JPC, Cincinnati, OH, July 2007.
- [20] Patterson, M., Foster, J., McEwen, H., Pencil, E., Van Noord, J. and Herman, D., "NEXT Multi-Thruster Array Test - Engineering Demonstration," AIAA-2006-5180, 42nd JPC, Sacramento, CA, July 2006.

- [21] Pencil, E., Foster, J., Patterson, M., Van Noord, J., McEwen, H., Diaz, E., "Ion Beam Characterization of the NEXT Multi-Thruster Array Plume," AIAA-2006-5182, 42nd JPC, Sacramento, CA, July 2006.
- [22] McEwen, H., Foster, J., Pencil, E., Patterson, M., Diaz, E. and Van Noord, J., "Characterization of Plasma Flux Incident on a Multi-Thruster Array," AIAA-2006-5183, 42nd Joint Propulsion Conference, Sacramento, CA, July 2006.
- [23] Foster, J., Patterson, M., Pencil, E., McEwen, H., Diaz, E. and Van Noord, J., "Plasma Characteristics Measured in the Plume of a NEXT Multi-Thruster Array," AIAA-2006-5184, 42nd Joint Propulsion Conference, Sacramento, CA, July 2006.
- [24] Foster, J., Pencil, E., McEwen, H., Patterson, M., Diaz, E. and Van Noord, J., "Neutralizer Plasma Coupling in a NEXT Multi-Thruster Array," AIAA-2006-5184, 42nd Joint Propulsion Conference, Sacramento, CA, July 2006.
- [25] Aadland, R. S., Frederick, H., Benson, S. W., and Malone, S. P., "Development Results of the NEXT Propellant Management System," 54th JANNAF Propulsion Meeting, December 2005.
- [26] Soulas, G., et al., "NEXT Single String Integration Test Results," AIAA-2009-4816, 45th AIAA/ASME/SAE/ASEE Joint Propulsion Conference and Exhibit (JPC), Denver, CO, August 2009.
- [27] Crofton, M., et al., "Characterization of the NASA NEXT Thruster," AIAA-2009-4815, 45th AIAA/ASME/SAE/ASEE Joint Propulsion Conference and Exhibit (JPC), Denver, CO, August 2009.
- [28] Herman, D., Soulas, G. and Patterson, M., "Status of the NEXT Long-Duration Test After 23,300 Hours of Operation," AIAA-2009-4917, 45th AIAA/ASME/SAE/ASEE Joint Propulsion Conference and Exhibit (JPC), Denver, CO, August 2009.

APPENDIX A

Specification sheets on the components of the Ion Propulsion system follow.

Thruster Data Sheet

Power Processing Unit Data Sheet

Propellant Management system Assemblies Data Sheet

Gimbal Data Sheet

NEXT — Thruster Data Sheet

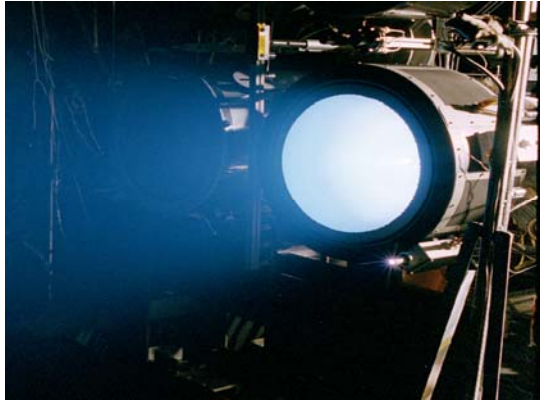

PM1— Flight Prototype Thruster

Performance Characteristics	
Thruster Power Range, kW	0.5-6.9
Max. Specific Impulse, sec	4190
Thrust, mN	26-236
Max. Thruster Efficiency	71%
Beam Diameter, cm	36
Max. Beam Current, A	3.52
Max. Beam Voltage, V	1800
Mass (with harness), kg	13.5

Tested to Qualification-Level Environments	
Vibration	10 G _{rms} 2 min/axis
Thermal/Vacuum	-120 to +215°C 3 full cycles 3 hot and 3 cold thruster starts 24 h dwell at +215°C

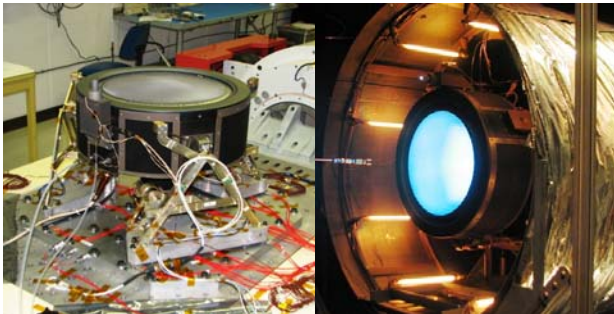
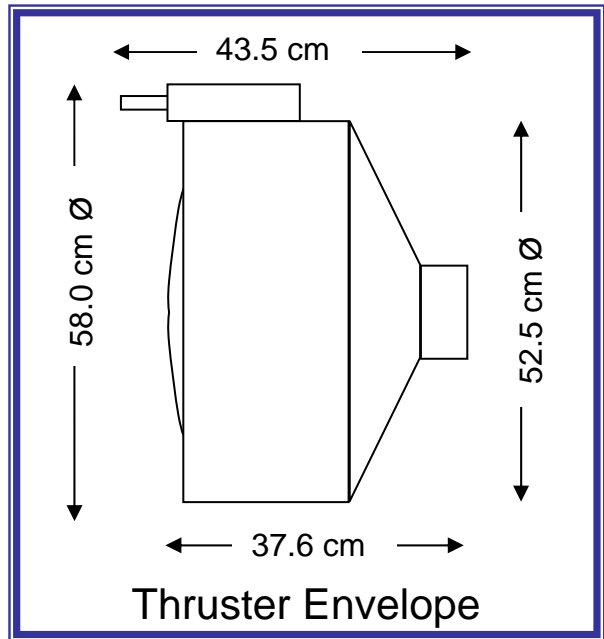

Thruster Rated Lifetime Expenditure vs. Input Power

Input Power	Lifetime, % life / khr
<1000 W	3.4
1000-2000 W	0.7
2000-3100 W	2.1
3100-4000 W	2.7
>4000 W	4.1

Lifetime Capability	
<ul style="list-style-type: none"> • Projected first failure: <ul style="list-style-type: none"> ○ >750 kg xenon throughput (at all throttle points > 1 kW input power) ○ >500 kg rated capability • Thruster lifetime margin <ul style="list-style-type: none"> ○ Must be determined through analysis of a specific mission throttle profile ○ Accompanying table provides a coarse, conservative estimate of thruster rated lifetime expended as a function of operating time within given input power ranges 	<p><i>Lifetime projections based on modeling, analysis and test results to date.</i></p> <p><i>Rated capability assumes 1.5X qualification factor</i></p>

NEXT Throttle Table (Beginning-of-Life)				
Beam Voltage, V	Thrust, mN	I_{sp}, s	Efficiency %	Input Power, kW
Xenon Flow = 5.79 mg/sec; Beam Current = 3.52 A				
1800	236.4	4165	70.1	6.888
1567	220.7	3889	69.2	6.080
1396	208.4	3672	68.4	5.487
1179	191.6	3374	66.9	4.735
Xenon Flow = 5.15 mg/sec; Beam Current = 3.10 A				
1800	208.2	4124	69.2	6.082
1567	194.4	3850	68.3	5.371
1396	183.6	3635	67.5	4.849
1179	168.7	3341	66.0	4.187
Xenon Flow = 4.52 mg/sec; Beam Current = 2.70A				
1800	181.4	4091	68.5	5.312
1567	169.3	3819	67.6	4.692
1396	159.9	3606	66.7	4.238
1179	146.9	3314	65.2	3.661
1021	136.7	3082	63.7	3.242
Xenon Flow = 3.99 mg/sec; Beam Current = 2.35 A				
1800	157.8	4037	67.4	4.637
1567	147.4	3769	66.5	4.098
1396	139.2	3559	65.6	3.702
1179	127.9	3270	64.1	3.200
1021	118.9	3042	62.6	2.835
Xenon Flow = 3.32 mg/sec; Beam Current =2.00 A				
1800	133.7	4105	66.9	4.022
1567	124.8	3833	65.9	3.560
1396	117.9	3619	64.9	3.223
1179	108.3	3326	63.2	2.797
1021	100.7	3093	61.4	2.488
Xenon Flow = 2.75 mg/sec; Beam Current =1.60 A				
1800	106.9	3959	63.7	3.260
1567	99.9	3696	62.6	2.891
1396	94.3	3490	61.6	2.621
1179	86.7	3207	59.8	2.280
1021	80.6	2983	58.0	2.033
Xenon Flow = 2.17 mg/sec; Beam Current =1.20 A				
1800	80.2	3767	60.5	2.449
1567	74.9	3517	59.5	2.172
1396	70.7	3321	58.5	1.969
1179	65.0	3052	56.8	1.714
1021	60.4	2838	55.0	1.528
936	57.8	2716	53.9	1.429
850	55.1	2585	52.5	1.330
679	49.2	2309	49.3	1.130
650	48.1	2260	48.7	1.095
400	37.2	1751	40.1	0.798
300	31.9	1499	34.6	0.678
Xenon Flow = 1.98 mg/sec; Beam Current =1.00 A				
275	25.6	1320	30.0	0.554

NEXT — Power Processing Unit Data Sheet

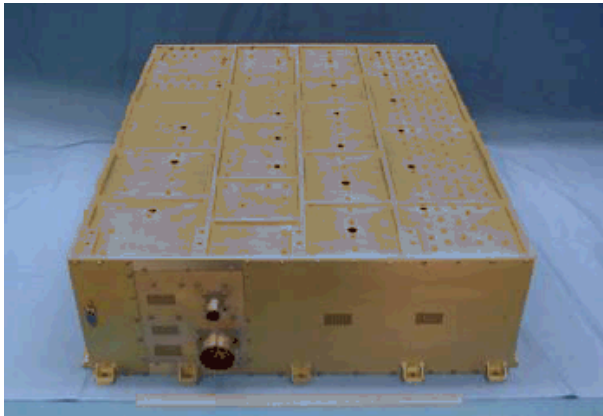

Performance Characteristics	
Input Power Range, W	250-7200
Peak Efficiency	95%
Primary Power Input Voltage Range, V	80-160
Housekeeping Power Input Voltage, V	28
Housekeeping Power, W	16-28
Mass, kg	33.9

Environmental Requirements	
Vibration	14.1 G _{rms}
Thermal	
Operating temperature*	-15 to +50°C
Survival temperature*	-40 to +70°C

*Allowable temperatures at the baseplate interface to the spacecraft

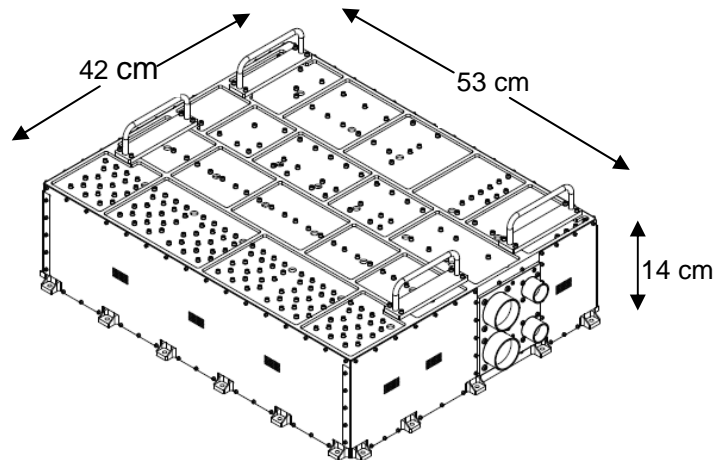

PPU Envelope

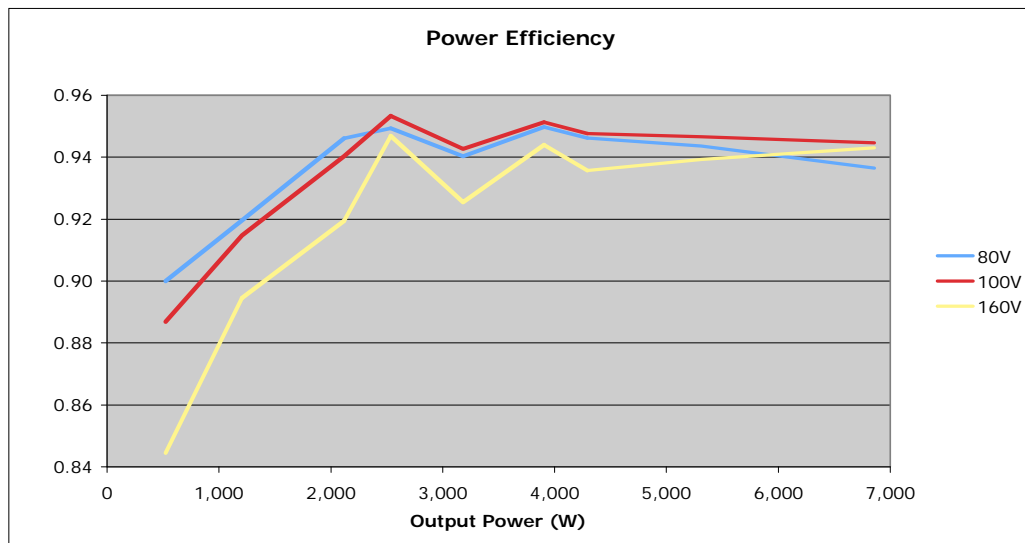

NEXT — Propellant Management System Assemblies Data Sheet

High Pressure Assembly (HPA): Pressure stepdown from tank pressure to nominal operating pressure



Low Pressure Assembly: Xenon flow control to the three inlets on the NEXT thruster

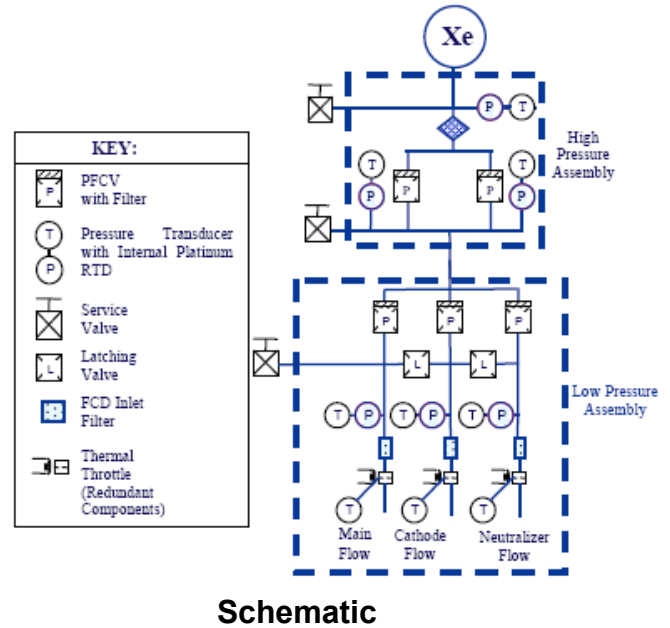
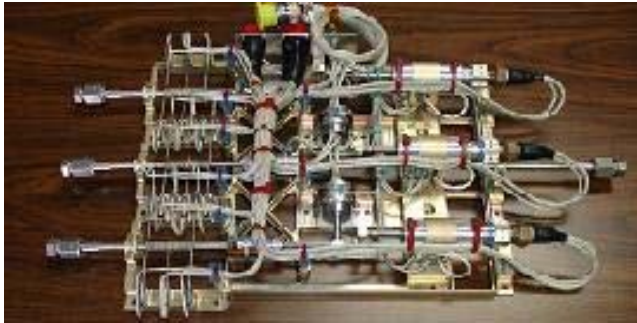

Tested to Qualification-Level Environments	
Vibration	14.1 G _{rms} 2 min/axis
Thermal/Vacuum	-12 to +70°C 3 full cycles 24 h of operations at -12 °C and +70°C

Performance Characteristics	
HPA Mass, kg	1.9
LPA Mass, kg	3.1
HPA Dimensions, cm	33x18x7
LPA Dimensions, cm	44x28x7
HPA Power Consumption, W	1.6
LPA Power Consumption, W	8.1
Flow Rate Accuracy	<3%
HPA Inlet Pressure, psia	<2700
Tank unusable residual xenon	<1%

LPA Operating Modes

Nominal:

- Pressure Control Loop
 - Fixed thermal throttle temperature
 - Variable PFCV orifice to control pressure and calibrated flow rate

Fault Mode

- Thermal Control Loop
 - Fixed PFCV orifice and internal pressure
 - Variable thermal throttle temperature to control flow rate
 - Allows control of multiple thruster flows with one or two PFCVs by opening cross-over latch valves.
 - LPA power consumption is higher in fault mode than in normal mode

NEXT —Gimbal Data Sheet



- Three strut attachment to spacecraft
- Thruster retention in launch position
- Thruster deployed to raised operation position after launch.

Performance Characteristics	
Mass, kg	6
X-Axis Range of Motion, Degrees	±19
Y-Axis Range of Motion, Degrees	±17
Slew rate, degrees/sec	>0.6

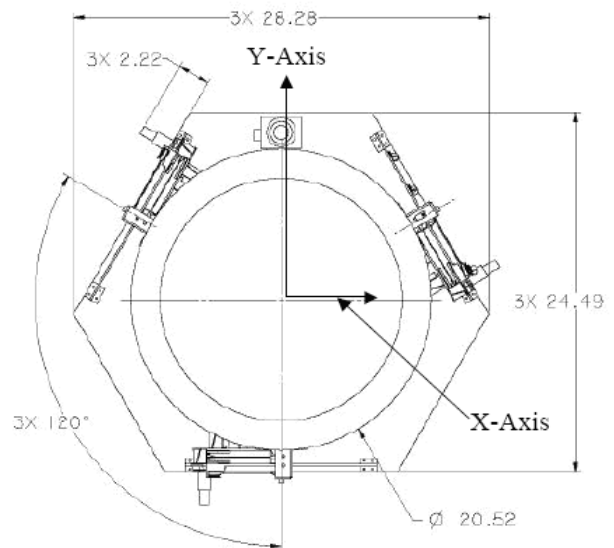

Gimbal mounting envelope

Tested to Qualification-Level Environments	
Vibration (in thruster/gimbal assembly)	10 G _{rms} 2 min/axis

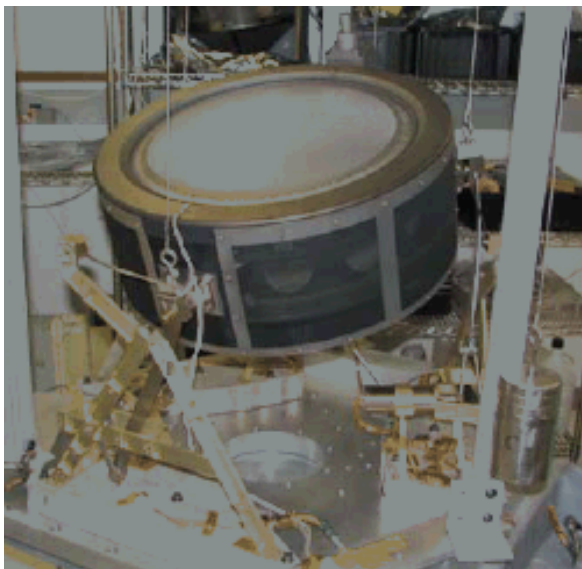

Post-vibration functional testing